

Vibration

Trouble shooting of vibration

1 Preliminary checkup

Tire visual inspection

- ① Wear irregularity
- ② Remove foreign material
- ③ Check air pressure

Rim visual inspection

- ① Check external damage or foreign material
- ② Check Wheel bearing gap by shaking wheel
- ③ Check over-abundance of lubricate
(could occurred by slipping between rim and tire)

Adjust dynamic balance

- ① Adjust dynamic balance below 5g
- ② Check road condition and vehicle maintenance

2 Check vehicle R.R.O.

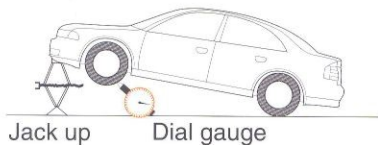

3 If not the R.R.O. problem, re-adjust balance

4 Check mis-assembly of tire and rim

5 How to measure R.R.O

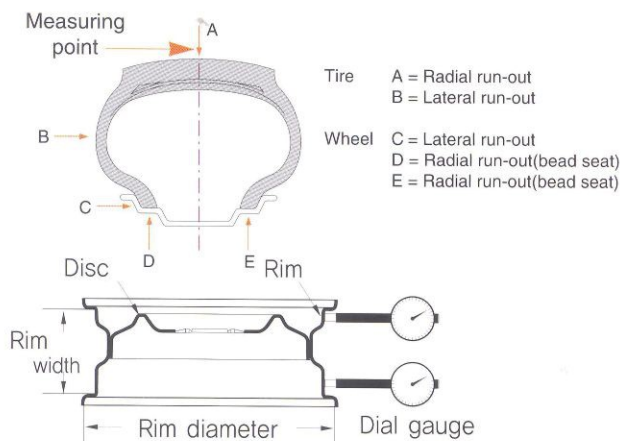

6 Matching tire and rim (tire high point + rim low point)

7 Check hole of rim, hub of wheel

